

# AVION WATER CO BLOWOFF ASSEMBLY

For In Pavement Applications

Mainline	Blowoff
8"	2" Blowoff
10" & 12"	4" Blowoff
14" to 36"	Site Specific See Plans

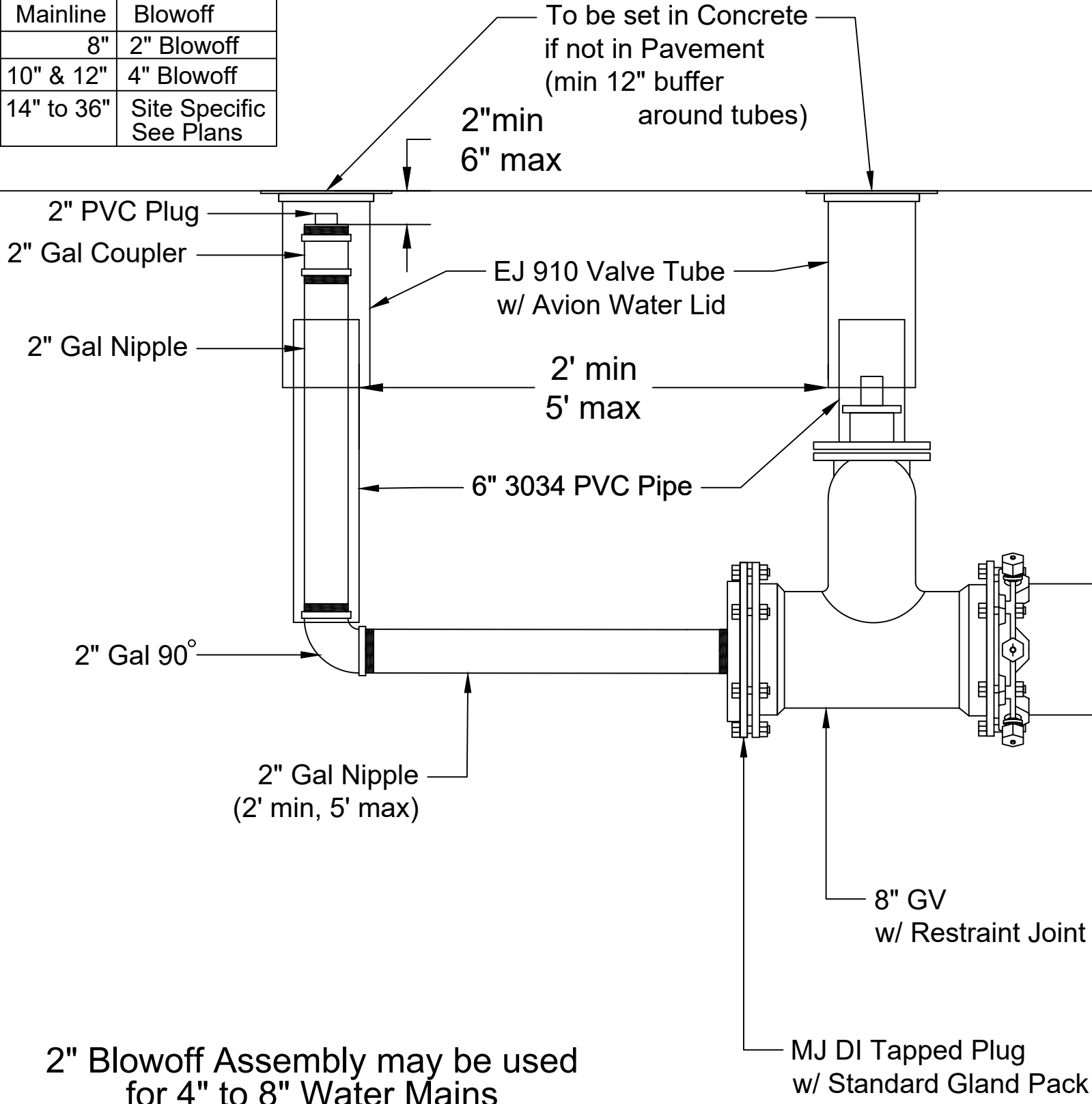

DWN BY: TEL

DATE: April 2026

Avion design specifications do not relieve the developer, engineer, or contractor from responsibility to design and construct the water system in accordance with good engineering and construction practices. Must adhere to OAR 333-061-0050 Construction Standards.

**AVION WATER CO**  
60813 PARRELL RD BEND, OR 97702

**2" BLOW OFF**

NOT TO SCALE

REV/DATE	
REV/DATE	
REV/DATE	