

AVION REQUIRES THE SENSUS CORDONEL WATER METER FOR 1.5" AND 2" APPLICATIONS
 AVION WATER USES THE "HOT ROD" AMR METER READING SYSTEM ON ALL METERED SERVICES
 ALL METERS SHALL INCLUDE A "HOT ROD" RADIO TRANSMITTER UNIT
 (WITH THE NICOR ADAPTER) AND BATTERY

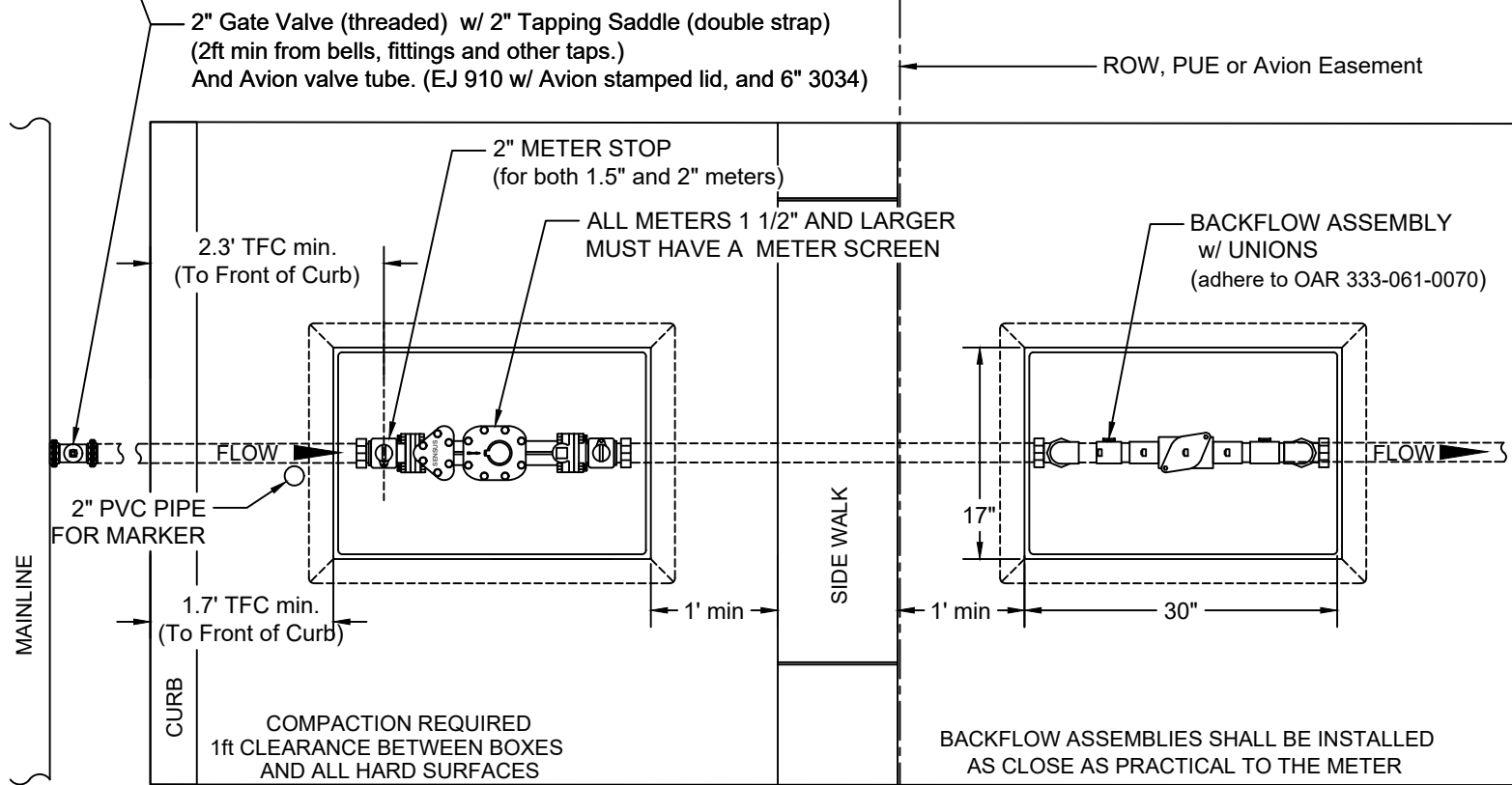
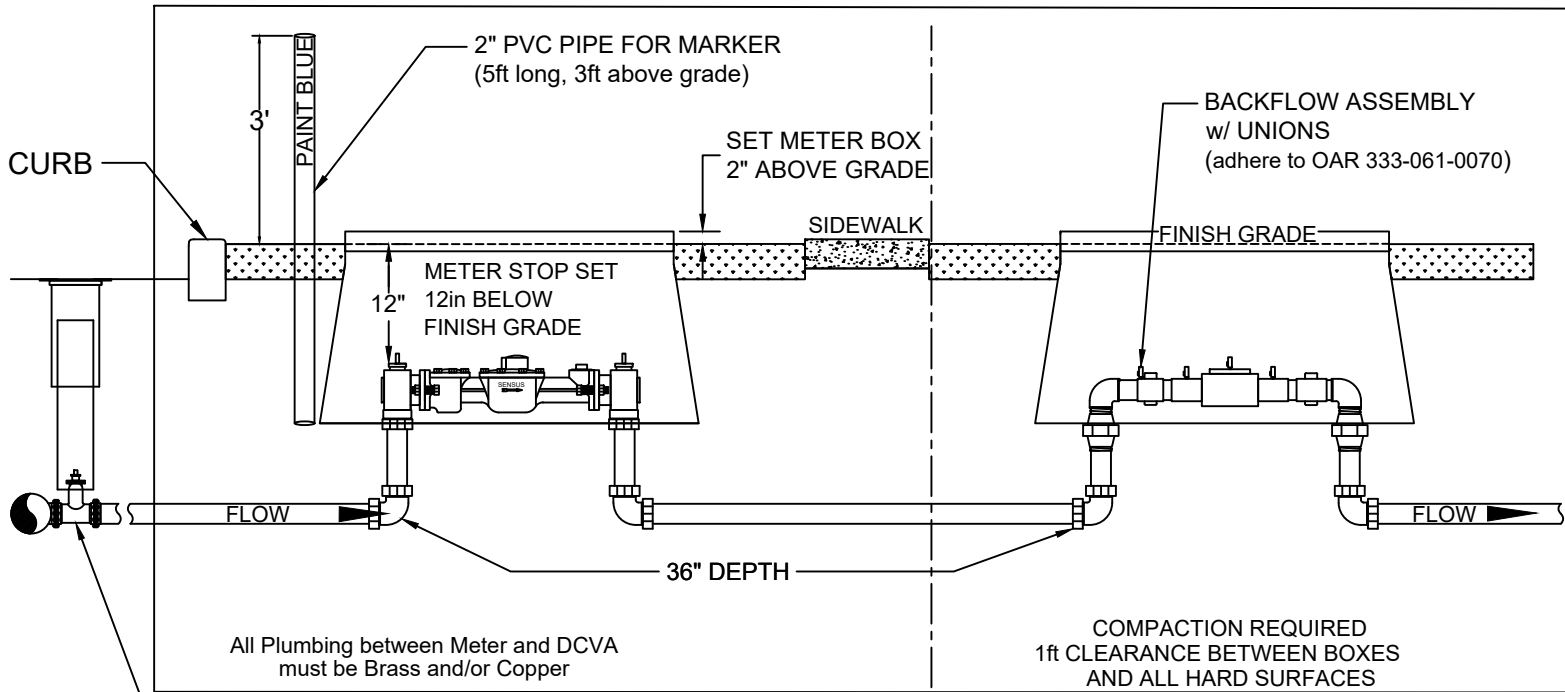

SEE POLICY FOR SERVICES FOR METER/BPA BOX AND LID SPECIFICATIONS

DWN BY: TEL

DATE: NOV 2024

Avion design specifications do not relieve the developer, engineer, or contractor from responsibility to design and construct the water system in accordance with good engineering and construction practices. Must adhere to OAR 333-061-0050 Construction Standards.

AVION WATER CO
 60813 PARRELL RD BEND, OR 97702

1 1/2" & 2" METER INSTALLATION

NOT TO SCALE	
REV/DATE	
REV/DATE	
REV/DATE	